

ROCHELEAU



Novelties
1st quarter 2023

TABLE OF CONTENTS



FOLD-SLIDE DOOR SYSTEM

04-05



FLAP OPENING SYSTEM

06-07



DECORATIVE HARDWARE
DECO 23 & VIEFE 23

08-09



FTP DECORATIVE
PANELS

10-11



SLIM WALL STORAGE SYSTEM

12-13



FLOAT MODULAR SYSTEM

14-15



UNDERMOUNT SLIDES SYSTEM

16-17



WASTE MANAGEMENT

18-20



CABINET LEVELLERS

21



DRAWER DIVIDER SYSTEMS

22-23



DRAWER SYSTEMS
GRASS NOVA PRO SCALA

24-26

FOLD-SLIDE DOOR SYSTEM

GLIDER T909A

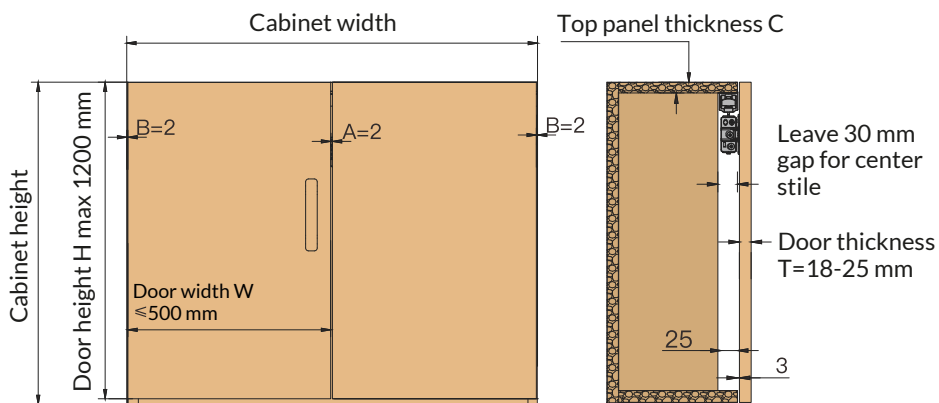

PRODUCT DESCRIPTION

The Glider T909A fold-slide system is a reliable and robust folding doors mechanism, which allows smooth and silent opening and does not require a bottom rail. With minimal clutter, it can be installed alone or combined with a second mechanism to have 2 pairs of folding doors on the same rail.

ADVANTAGES AND BENEFITS

The Glider T909A fold-slide system is composed solely of a kit containing all the hardware for a pair of doors with a maximum height of 1200 mm (47 1/4"), and a top rail of 1.5 m (59") or 3 m (118"). Center and side hinges can be added to the system for taller doors but still under the 15 kg (33 lbs) per door limit.

TECHNICAL SPECIFICATIONS

- › Compatible with wooden or aluminum frame door
- › Capacity: 15 kg/ door
- › Required door thickness: 16-25 mm
- › Maximum door height: 1200 mm
- › Maximum door width: 500 mm
- › No contact between door and cabinet while opening
- › 90° door opening limitation
- › Integrated self-locking system when door is opened

PRODUCT CODES

| DESCRIPTION | CODE |
|--------------------|-----------------|
| T909A hardware kit | SCM-KITT909A |
| 1,5 m top rail | SCM-RAIT909A15M |
| 3 m top rail | SCM-RAIT909A3M |
| Central hinge | PEN-T909AC |
| Lateral hinge | PEN-T909AL |

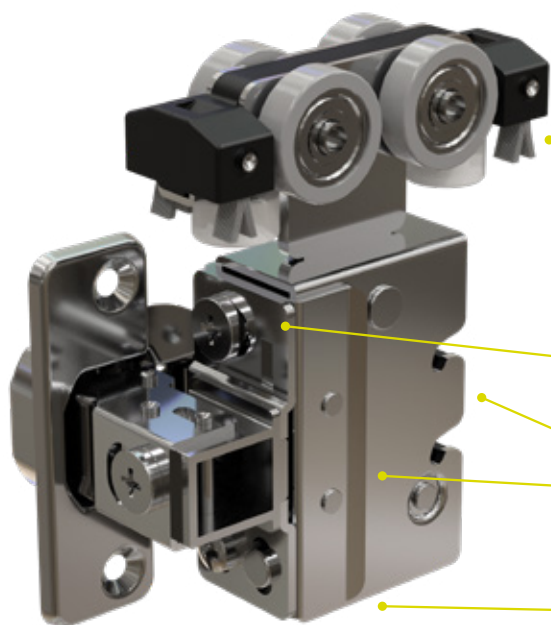
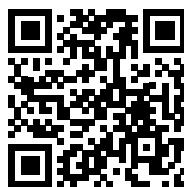

Brush device on roller for cleaning dust in rail

Depth and height adjustments

Reversible system for left or right mounting

Anti-detachment door locking system



FLAP OPENING SYSTEM

SQ SERIE FROM DTC



PRODUCT DESCRIPTION

DTC's SQ Series flap opening systems are now available in a touch-open version in addition to the standard soft-closing version. Regardless of the opening or closing mechanism, the SQ system is very compact and fits perfectly into all styles of furniture.

ADVANTAGES AND BENEFITS

In addition to conventional door adjustments (vertical / horizontal / depth), the SQ system offers fine adjustment of the spring force to guarantee a hold in any position of the door. Each lifting system is available with 2 types of cover, white or anthracite, to match the cabinet. Angle limiters are also available to prevent the risk of collision with a molding or a ceiling over the cabinet.

TECHNICAL SPECIFICATIONS

- › Opening angle: 107°
- › 70° or 100° angle limiter available
- › Tested on 60 000 cycles
- › Magnetic ejector included
- › Door height: 250 to 500 mm (10" to 19 5/8")
- › Maximum door width: 1200 mm (47")
- › Door thickness: 16 to 28 mm (5/8" to 1 1/16")
- › Minimum depth installation : 240 mm (9 1/2")

PRODUCT CODES

| DESCRIPTION | CODE |
|----------------------|----------|
| Light weight system | BRA-PDTL |
| Medium weight system | BRA-PDTM |
| Heavy weight system | BRA-PDTH |

DECORATIVE HARDWARE

DECO 23 & VIEFE 23

THE DISTINCTIVE TOUCH TO YOUR PROJECTS

It is with great enthusiasm that we present you the 2023 edition of our decorative catalog. As a bonus this year, the addition of several unique and original models of wall hooks as well as the new models of handles and knobs. Déco 2023 will certainly be a must to help you find that little extra to add on your cabinets.



NORTH AMERICA VIEFE COLLECTION

In addition to the Déco 2023 and its many choices, Rocheleau also offers the entire Viefe 2023 North American collection. This range, with a modern design directly from Spain, includes more than 800 different models that will surely enhance the design of your kitchen, bathroom or other...



FTP DECORATIVE PANELS

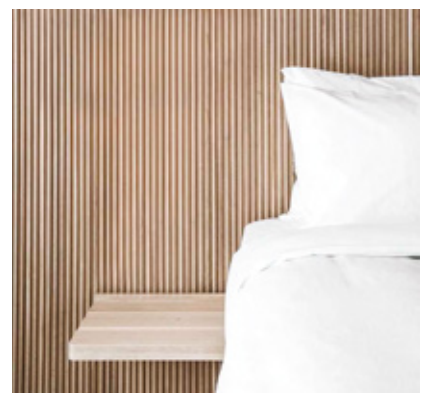
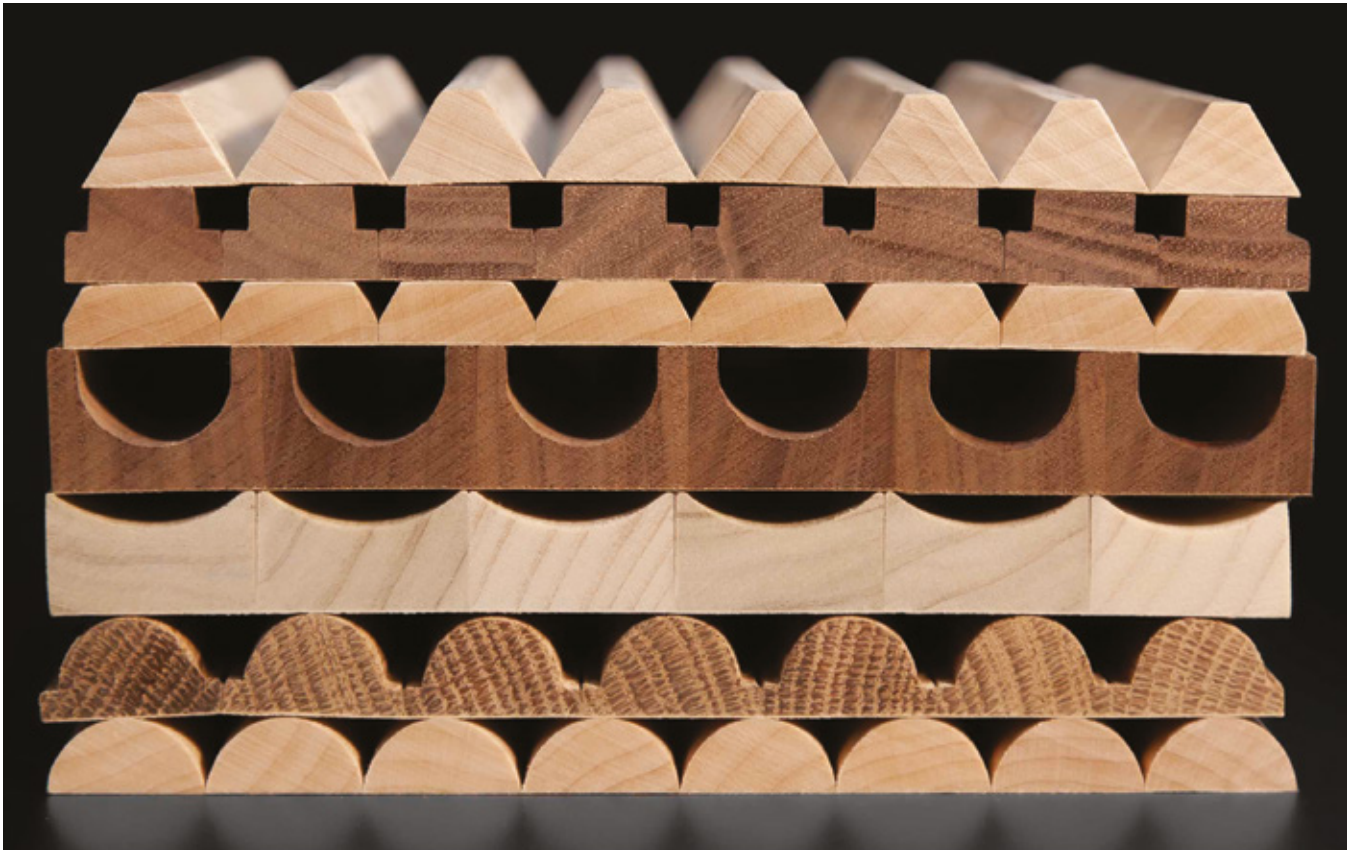

PRODUCT DESCRIPTION

Flexible tambour panels offer a versatile design and many possibilities. Glued on a special 3M paper backer, they can be wrapped around a surface or mounted on a curved area. With its different designs and wood species, these flexible tambour panels will enhance your project.

TECHNICAL SPECIFICATIONS

- › 7 different designs
- › 33 different slat dimensions
- › 10 wood essences: Mahogany, Alder, Hickory, Cherry, White oak, Red oak, Maple, Walnut, Poplar, Pine
- › 48" x 96" panels (the dimension of the panels may vary according to the dimensions of the slats)
- › Slats arranged vertically or horizontally
- › Other panel sizes also available on request

PRODUCT CODES

| DESCRIPTION | CODE |
|----------------------|-------------|
| Serie 100 FTP panels | Z-FTP-10... |
| Serie 200 FTP panels | Z-FTP-20... |
| Serie 300 FTP panels | Z-FTP-30... |
| Serie 400 FTP panels | Z-FTP-40... |
| Serie 500 FTP panels | Z-FTP-50... |
| Serie 600 FTP panels | Z-FTP-60... |
| Serie 700 FTP panels | Z-FTP-70... |



WALL STORAGE SYSTEM

SLIM



Slim is a customizable, versatile, and easy to install aluminum wall storage system with unlimited application possibilities: closet storage, bookcase shelving, room divider, commercial display, and more.

The simplicity of this system lies in its rectilinear aesthetics which results in an elegant furnishing solution.





The placement of the structure adapts to different creative ideas, whether for a very stable installation on the floor, ceiling, or wall.

The new Rocheleau online configurator makes it easy and quick to create unique layouts.

The custom cutting service gives you the opportunity to receive a ready-to-assemble concept. All you have to do is add to add the shelves and/or the boxes.

MODULAR SYSTEM

FLOAT



Float is a fully modular aluminum system that easily creates unique and multifunctional shelving structures and furniture inserts. Designed for both residential and commercial needs, this open concept storage has multiple applications and responds to the growing popularity of custom and open designs.



This type of structure stands out for its great versatility and lets everyone's imagination flow freely to create unique designs. Its connection design guarantees a robust and durable fixing while being simple and quick to make.

UNDERMOUNT SLIDES SYSTEM

S32 AND S32P SERIES



PRODUCT DESCRIPTION

S32 Series undermount slides offer incomparable value for money. Equipped with an efficient synchronization system ensuring smooth opening and closing coupled with an integrated damper mechanism, they are perfect for any budget.

ADVANTAGES AND BENEFITS

Available in industry standard sizes, installation is quick and easy. Its improved movement as well as its height, width and depth adjustments ensure a clean and precise result.

TECHNICAL SPECIFICATIONS

- › Brackets included
- › Synchronized
- › Full extension
- › Load capacity of 40 kg
- › Integrated damper
- › Height adjustment: +3 mm / Lateral adjustment: $\pm 1,5$ / Depth adjustment: +5 mm
- › Available from 250 mm to 600 mm for the soft-close version
- › Available from 350 mm to 550 mm for the touch-open version



PRODUCTS CODES

| DESCRIPTION | CODE |
|---|-------------|
| S32 series undermount slide, soft-close | COU-S32... |
| S32 series undermount slide, touch-open | COU-S32P... |
| Synchronization rod for S32P slides | SYN-BARS32P |

WASTE MANAGEMENT

WRB WASTE BINS



12" WASTE BIN

16" WASTE BIN

18" WASTE BIN

| MODEL | MINIMUM HEIGHT | MINIMUM WIDTH (FRONT FIXING) | MINIMUM WIDTH (HANDLE) | MINIMUM DEPTH |
|-------------------|------------------|------------------------------|------------------------|-------------------|
| 12" WRB Waste bin | 605 mm (22 3/8") | 253 mm (10") | 235 mm (9 1/4") | 472 mm (18 3/4") |
| 16" WRB Waste bin | 506 mm (18 1/2") | 345 mm (13 3/8") | 320 mm (12 1/2") | 472 mm (18 3/4") |
| 18" WRB Waste bin | 605 mm (22 1/2") | 397mm (15 1/2") | 380 mm (15") | 522 mm (20 9/16") |



PRODUCT DESCRIPTION

The WRB pull-out recycling center is installed at the bottom of the cabinet and offers 2 options: opening with door-mounted brackets, or with the integrated handle. Equipped with undermount soft-close slides, it offers a really interesting value for money.

TECHNICAL SPECIFICATIONS

- › Bins: included
- › Individual covers: included
- › Bins volume: 1x 35 L / 2 x 27 L / 2 x 35 L
- › Load capacity: 30 kg (66 lbs)
- › Slide type: undermount
- › Slide extension type: Full extension
- › Closing type: Soft-close
- › Finish: anthracite
- › Slide mounting type: Bottom mounted
- › Installation: Independent or on the door

PRODUCT CODES

| DESCRIPTION | CODE |
|-------------------|------------|
| 12" WRB waste bin | POU-WRB300 |
| 16" WRB waste bin | POU-WRB400 |
| 18" WRB waste bin | POU-WRB450 |



WASTE MANAGEMENT

DB WASTE BINS



TECHNICAL SPECIFICATIONS

- › Bins: Included
- › Plastic cover: Included
- › Bins volume: 2 x 20 L
- › Slide type: Ball bearing slide
- › Slide extension type: Over extension
- › Soft closing
- › Slides load capacity: 30 kg
- › Finish: Grey
- › Mounting type: Bottom mounted
- › With or without front-fixing brackets

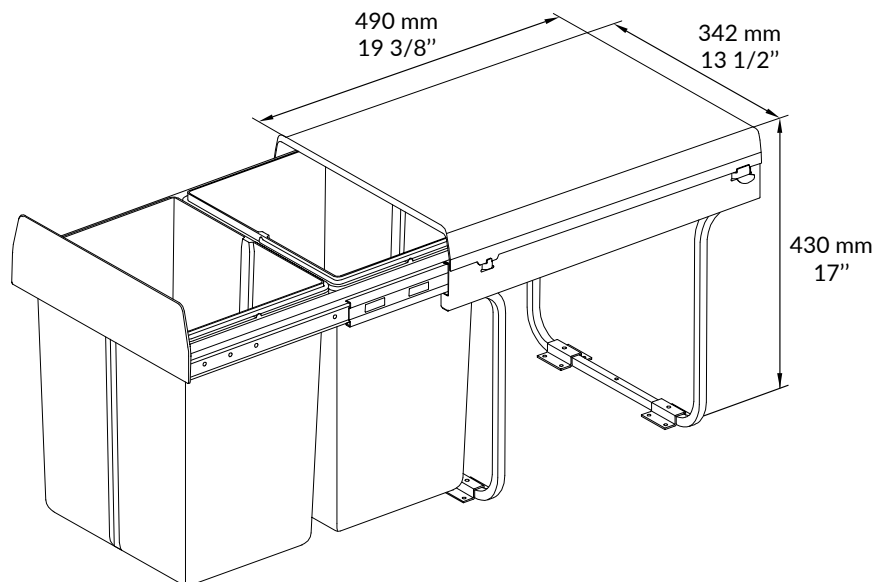

CABINET LEVELLERS

MT180 FOLDABLE LEVELLERS

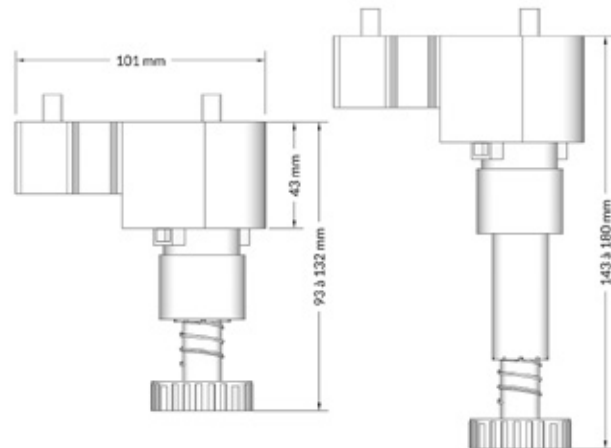
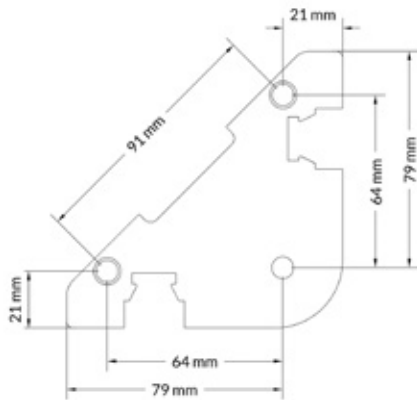

TECHNICAL SPECIFICATIONS

- › Height: Adjustable from 93 to 180 mm
- › Dimensions top of the leg: 101 mm x 101 mm
- › Load capacity: 350 kg / leg
- › Material: ABS

PRODUCT CODES

| DESCRIPTION | CODE |
|--------------------------------------|------------|
| MT180 foldable leveller, screw-on | NIV-MT180V |
| MT180 foldable leveller, 8 mm dowels | NIV-MT180G |



DRAWER DIVIDER SYSTEMS

MODULAR DIVIDERS



PRODUCT DESCRIPTION

This Modular drawer divider allows, by combining it with one or more models from this series, to create personalized storage in your drawers. It also has a protective film to be removed when installing.

ADVANTAGES AND BENEFITS

In white or anthracite, the Modular dividers offer interesting storage solutions for your small and large utensils, and do not have to be adjusted to the exact width of the drawer interior.

TECHNICAL SPECIFICATIONS

- › Width: 240 / 266 / 273 / 376 mm
- › Height: 50 mm
- › Depth: 522 mm but can be cut down to 472 mm



400MM

A 240 B 266



450MM

A 240 B 266



500MM

A 240 B 266 C 376



600MM

B 266 + A 240 C 376 M 273



700MM

B 266 + A 240 C 376 M 273



800MM

C 376 + A 240 C 376 + B 266 B 266 + A 240 B 266 + M 273 M 273*2



900MM

C 376 + A 240 C 376 + B 266 B 266 + A 240 B 266 + M 273 M 273*2 C 376*2



DRAWER SYSTEMS

GRASS NOVA PRO SCALA



The new generation of Nova Pro Scala drawers is the perfect marriage between form and function and offers a wide variety of customization possibilities. Its quality, stability and the perfection down to the smallest details are unmatched. Nova Pro Scala: a step into the future!

DIFFERENT NEEDS, DIFFERENT POSSIBILITIES...

Offered in 6 different heights and 2 finishes, Ice and Stone, it will perfectly integrate to your kitchen, bathroom, office, or living room.

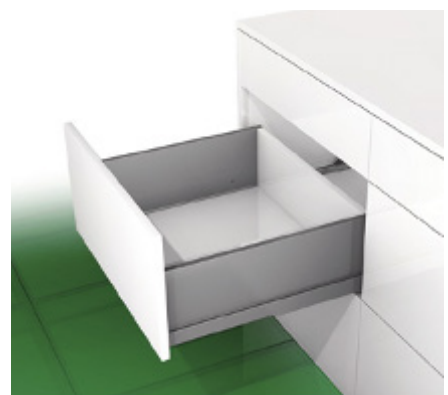
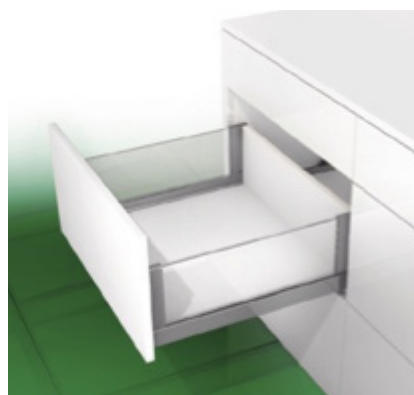
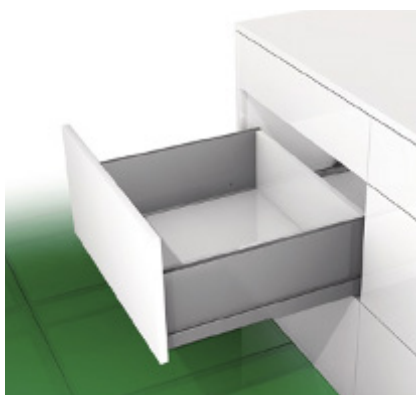
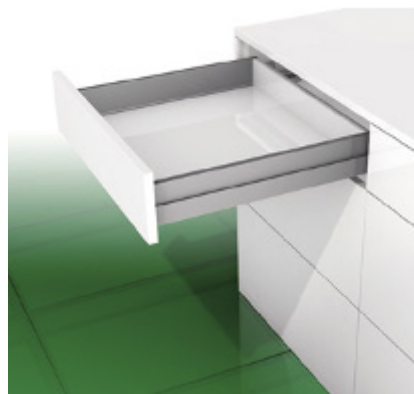
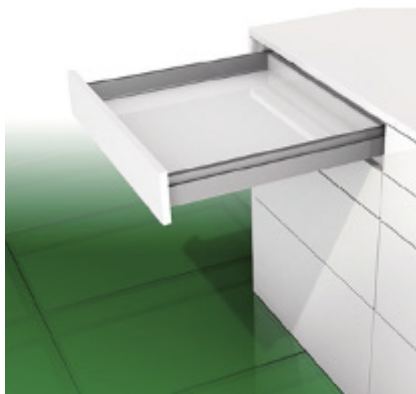

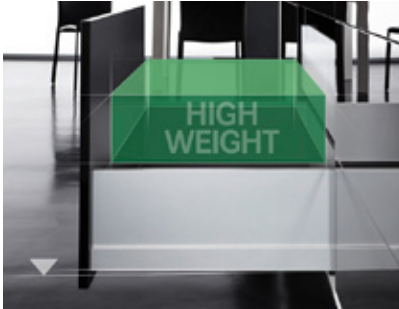

EXCELLENT STABILITY

The minimal deflection and the load capacity of 40/70 kg ensure a perfect movement, even with extra large and fully loaded drawers.

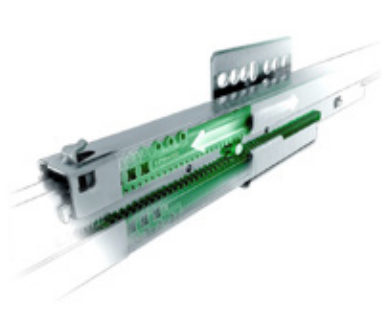

EXCELLENT SLIDING FEATURES

Smooth closing and opening.
100% synchronized

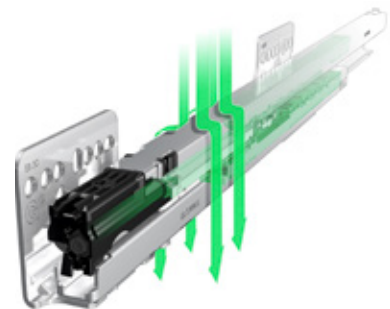

CLOGGING PROTECTION

The closed components don't let dust penetrate inside the slide during installation.

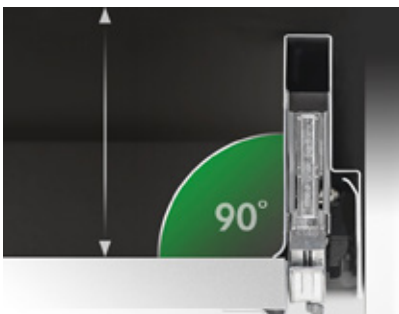

MORE SPACE FOR YOUR STORING

The minimal installation width and 90° interior side ensure an additional storage space inside the drawers.



WELDED BACK ADAPTER

Without additional parts.
Easy drawer mounting, no matter the drawer's height or width.

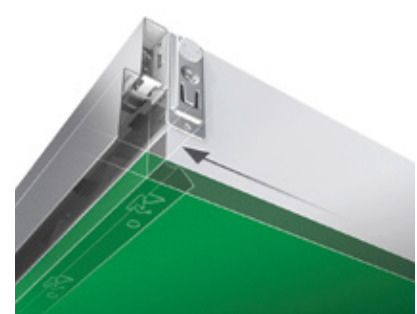

RATIONAL USE

Identical back and bottom width for optimal time saving when cutting.

THE DETAILS THAT MAKE THE DIFFERENCE

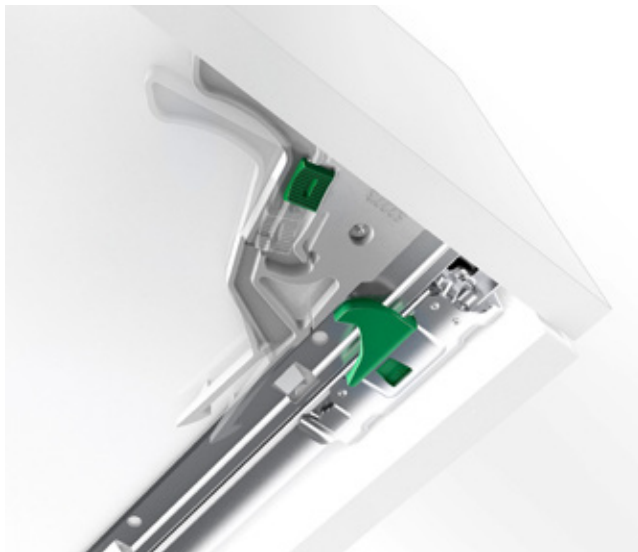

The Nova Pro Scala range is complete and includes many accessories that are really useful on different levels.

CHILD SECURITY

- › When activated, limits the opening of the drawer to a small gap; the drawer opens fully when a concealed lever at the base is operated
- › The concealed installation avoids imitation of the action by the child
- › Use of the drawer storage space is unrestricted
- › No damage to front and cabinet
- › Can also be retrofitted
- › Can be deactivated without tools if needed



TOUCH-OPENING SYSTEM

- › Mechanical opening system for handle-free fronts
- › Combines Tipmatic function with soft-close damping
- › Tool-free assembly of the Tipmatic soft-close unit
- › To be used with Nov Pro Soft-close full extension slides
- › One unit for all nominal lengths and weight classes
- › 3-stage adjustment of the opening force
- › Wide trigger range due to synchronisation rod SYN-BAR-TMSC

SPACER, INSET DRAWER CATCH AND BLIND SNAP-ON BRACKETS



**LIKE THESE MAJOR EUROPEAN BRANDS,
CHOOSE THE AUSTRIAN QUALITY OF GRASS**

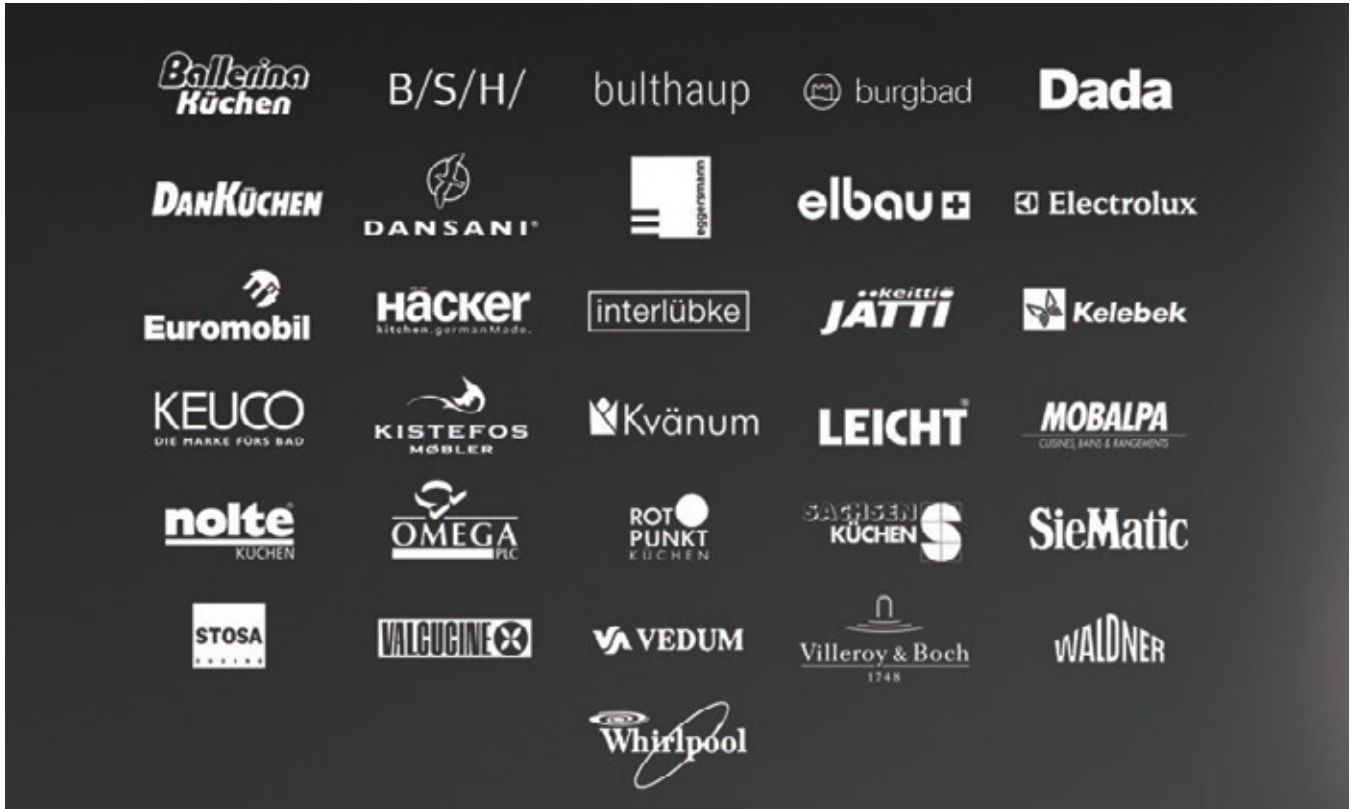

G*GRASS®





ROCHELEAU INC.

760, boul. Pierre-Roux E.
Victoriaville (Québec) G6T 1S6 CANADA

T 1-800-567-5201
@ sales@rocheleau.ca

ROCHELEAU.CA